

Front/base stabiliser for thin fronts

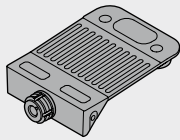

- For stabilising wide fronts and drawer bases
- Reinforces the connection between the drawer base and the front
- Recommendation:
Cabinet width KB > 600 mm: 1 item
Cabinet width KB > 900 mm: 2 items
Front height FH > 380 mm: 1 item

Order information

Fixing method	Colour	Part no.
EXPANDO T	RAL 7037 dust grey	Z96.00T1

Page instructions

Fixing system for thin fronts – EXPANDO T	554
Assembly recommendation and limitation of liability – EXPANDO T	555

Planning

Space requirement in cabinet

Drilling distances – front

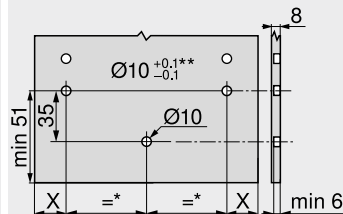
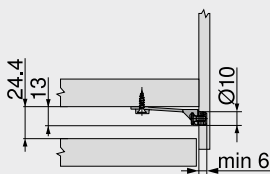

X = 14 mm + FA
 FA Front overlay
 * Min. 80 mm
 ** Stone and ceramic +0.2/-0.1 mm

Side stabilisation

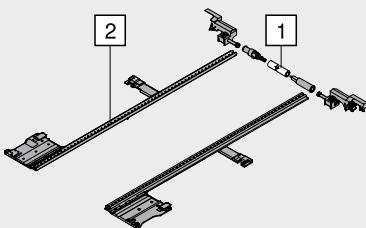

- Additional stabilisation for extra wide high fronted pull-outs
- Recommendation: cabinet width KB 900–1400 mm
- Aluminium rod suitable for KB up to 1400 mm, for cutting to size
- No additional space requirement at the bottom
- Suitable for use with BLUMOTION, SERVO-DRIVE, TIP-ON BLUMOTION and TIP-ON

Space requirement

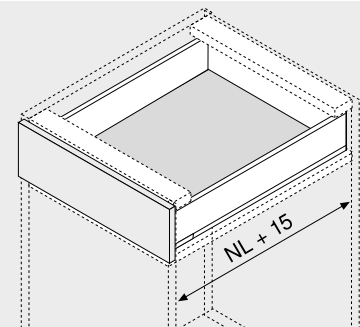

NL Nominal length

Order information

Side stabilisation

Nominal length NL (mm)	Part no.
270–400	ZS7M400LU
450–650	ZS7M650LU

Cutting

- 1 Internal cabinet width LW – 295 mm
- 2 Nominal length NL + 10 mm

Page instructions

Overview – LEGRABOX	205
Overview – assembly devices	561
More technical details	662