

Hinge systems

blum

- ▶ **MODUL – hinges**
- ▶▶ **Blind corner application**

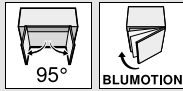

Blind corner hinge inset application

Webcode
DQE4MM



- Hinge for blind corner applications
- **MODUL BLUMOTION** with integrated **BLUMOTION** (with deactivation option)
- Slide on hinge arm
- Can only be combined with mounting plate 199.8130
- All metal hinge, nickel plated
- 95° opening angle
- 3-dimensional front adjustment

Application

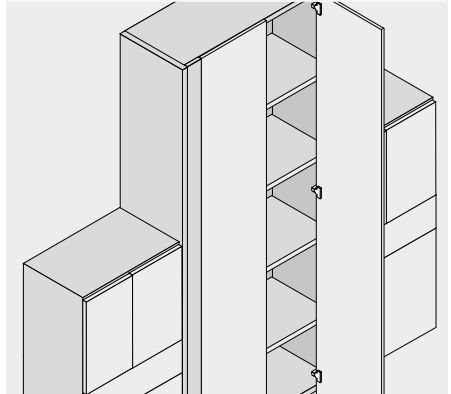

Order information

Inset application		
--------------------------	--	--

<input type="checkbox"/>	Boss	<input type="checkbox"/>	Screw-on
<input type="checkbox"/>	Hinge	<input type="checkbox"/>	Spring
	Part no.		
<input checked="" type="checkbox"/>	MODUL BLUMOTION	<input checked="" type="checkbox"/>	99B9550
<input type="checkbox"/>	With spring	<input type="checkbox"/>	Unsprung

	<input type="checkbox"/>	Cruciform mounting plate for blind corner applications
Spacing (mm)	Height (mm)	Part no.
3	12.2	199.8130

a	Accessories	
	<input type="checkbox"/>	Hinge arm cover cap
Print/Stamp	Logo	Part no.
Plain	–	90M2503
Stamped	Blum	90M2503.BP

a Accessories – general

	<input type="checkbox"/>	Hinge boss cover cap
Hinge		Part no.
MODUL BLUMOTION		70T3504

	<input type="checkbox"/>	Chipboard screws
Ø (mm)	Length (mm)	Part no.
3.5	15	609.1500
3.5	17	609.1700



Blind corner hinge inset application

Webcode
DQE4MM

Planning

Hinge dimensions and gap calculation based on factory setting (mounting plate spacing = 3 mm)

Hinge and front protrusion at full opening angle

Inset application

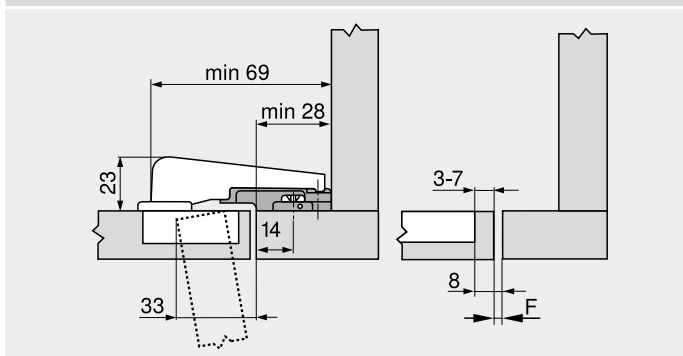

Fixing position from inside edge of muntin: 14 mm
Special mounting plate for blind corner application: 199.8130

F Gap

Minimum gap (F) for fronts with a front radius (R = 1 mm) based on the factory setting

Drilling distance TB (mm)	Front thickness FD (mm)											
	16	18	19	20	22	24	26	28	29	30	31	32
3	0.2	0.3	0.4	0.5	0.8	1.0	1.5	1.9	Δ	Δ	Δ	Δ
4	0.2	0.3	0.4	0.5	0.7	1.0	1.4	1.8	Δ	Δ	Δ	Δ
5	0.2	0.3	0.4	0.5	0.7	1.0	1.4	1.8	Δ	Δ	Δ	Δ
6	0.2	0.3	0.4	0.5	0.7	1.0	1.4	1.8	Δ	Δ	Δ	Δ
7	0.2	0.3	0.4	0.5	0.7	0.9	1.4	1.7	Δ	Δ	Δ	Δ

Δ In these cases a trial is recommended

Adjustment

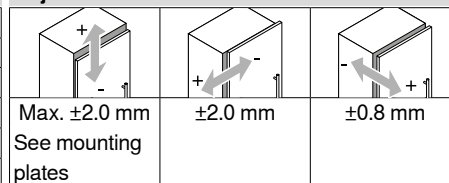

Screw-on

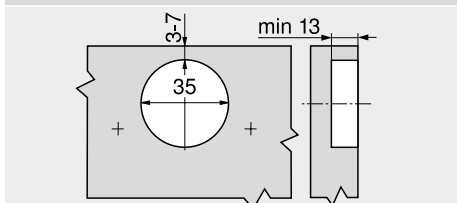

Hinge boss dimensions

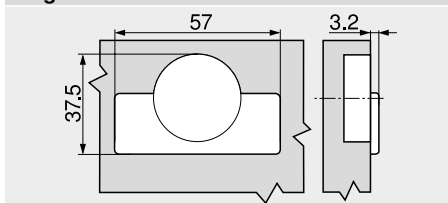

Page instructions

Overview – MODUL – hinges	199	More technical details	774
Mounting plates	206		
Accessories – hinge arm cover cap	209		
Accessories – general	210		
Assembly, removal and adjustment	212		
Overview – assembly devices	683		