

Royde & Tucker H131-402 HI-LOAD pivot set

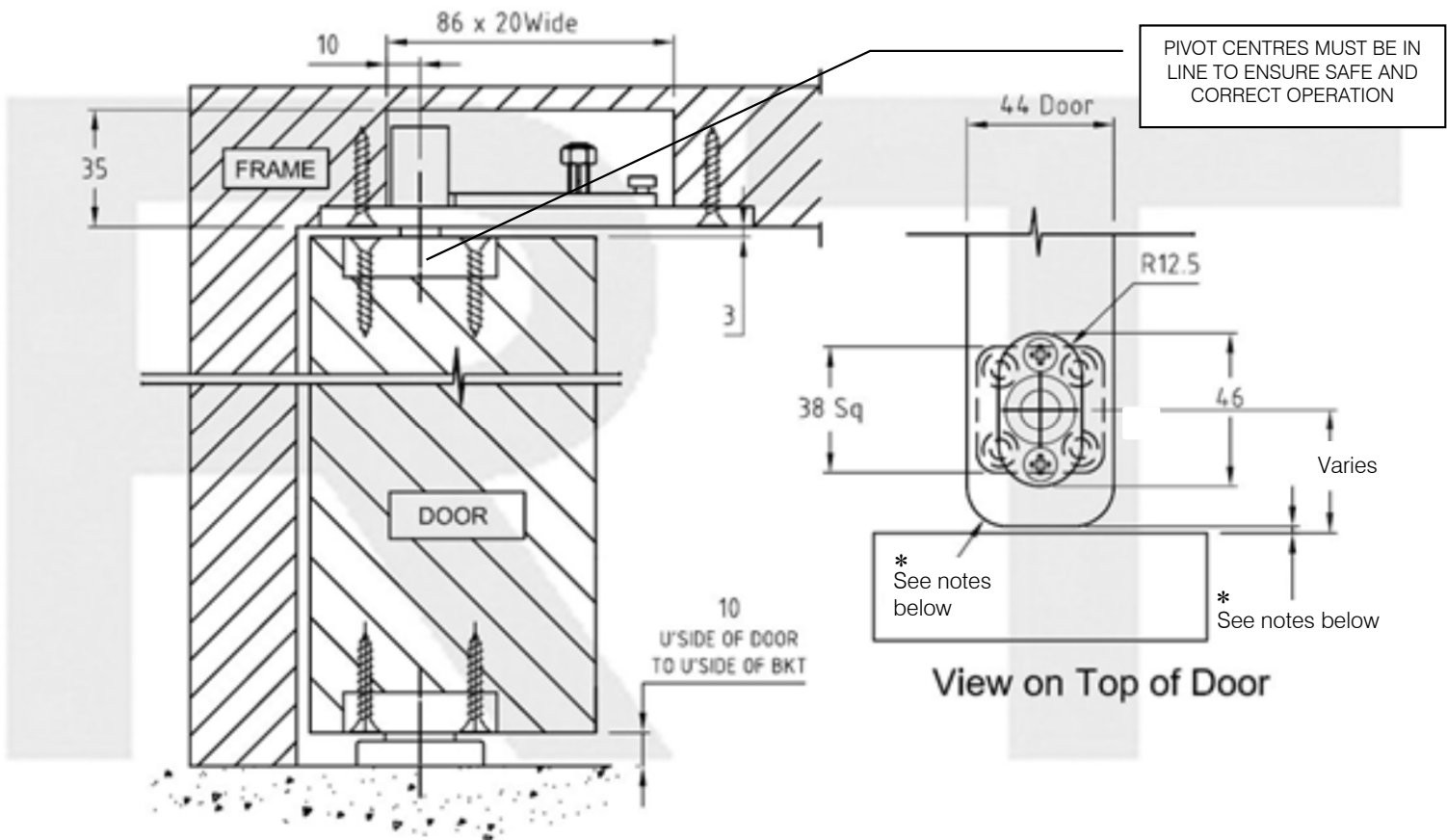
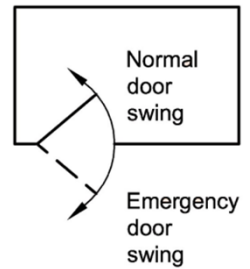

- Grade 304 stainless steel
- Allows the door to swing in either direction
- Maintenance free, guaranteed for 25 years
- Suitable for FD30 and FD60 doors, to BS 476 for both single and double door applications
- *For 44mm non FR doors an R9 radius is required on the pivot edge with a 4mm door and frame gap
- *For 44mm thick Fire doors an R15 radius is required on the pivot edge as only a 3mm gap is permitted between the door and frame.
- *For 54mm thick Fire doors an R20 radius is required on the pivot edge as only a 3.5mm gap is permitted between the door and frame.
- Bottom bracket is floor mounted and doesn't protrude beyond the doors face
- Medium duty for internal doors weighing up to 80kg and up to 1100mm wide
- Top and bottom door plates have HI-LOAD maintenance free oil impregnated bronze bearings
- Set includes door bottom pivot, top centre, door brackets and M5 x 30mm screws
- For adjustable unit see H131-452
- Note: Door plates radiused R12.5 for easier preparation

Royde & Tucker Ltd
 Bilton Road
 Cadwell lane
 Hitchin
 SG4 0SB
 Tel:01462 444444
 Fax:01462 444433
 www.ratman.co.uk
 e-mail: sales@ratman.co.uk